



# OÇES

## DOUBLE INLET RADIAL FANS / Forward Curved

### Fan Components and Material Properties

OÇES radial fan body is made of DKP sheet metal with electrostatic powder coating, the fans operate at high efficiency and low noise level. Uses asynchronous motor and device max. It is capable of carrying air at a temperature of 40°C.

### Fan Structure

It has double suction and forward curved radial fan type. The fan wheel is made of high quality galvanized steel which is resistant to corrosion and is manufactured in aerodynamic structure to ensure regular flow. Thanks to its aerodynamic wing structure, it works quietly.

### Benefits

It works with low noise levels and is designed to

be maintenance-free for long periods of time. Due to its frequent wing structure and efficient motor, it produces high flow rate and pressure compared to its dimensions. Provides advantages in areas where space is limited. Speed adjustable with speed control devices.

### Speed Control

Optional control devices can be provided. 1~phase products with linear voltage regulator speed control can be done. (see BSC accessory)

### Usage Areas

Greenhouses, factories, warehouses, paint shops, shopping centers, factories, plastic and packaging machines etc. It is used for ventilation of large places.

### Technical Drawing and Tables

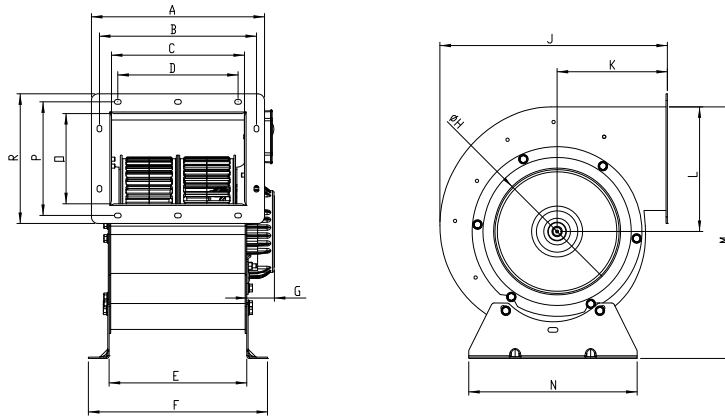

TYPE	A	B	C	D	E	F	G	H	J	K	L	M	N	O	P	R
OÇES	258	234	197	180	210	269	41	190	339	160	189	396	252	133	169	194

Dimensions are in (mm)

TYPE	VOLTAGE	FREQUENCY	POWER	CURRENT	CAPACITOR	SPEED	AIR FLOW	SOUND PRESSURE	INSULATION CLASS	PROTECTION CLASS	WEIGHT
	V	Hz	W	(A)	(µF)	r.p.m	m <sup>3</sup> /h	dB(A)	Ins.cl.	IP	kg
OÇES	230	50	400	1,8	10	1250	2200	45	B	44	10,3

The sound level is measured at a distance of 3 m in open field condition.

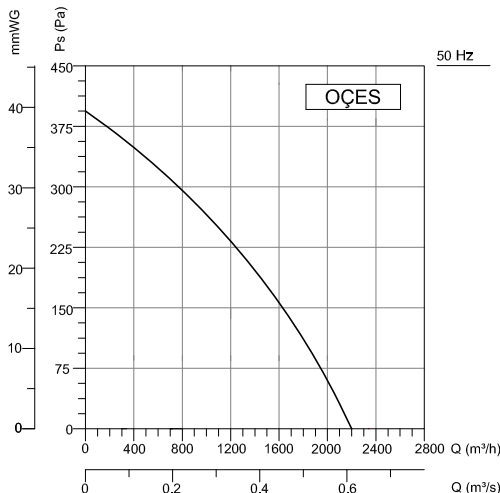

### Accessories

